



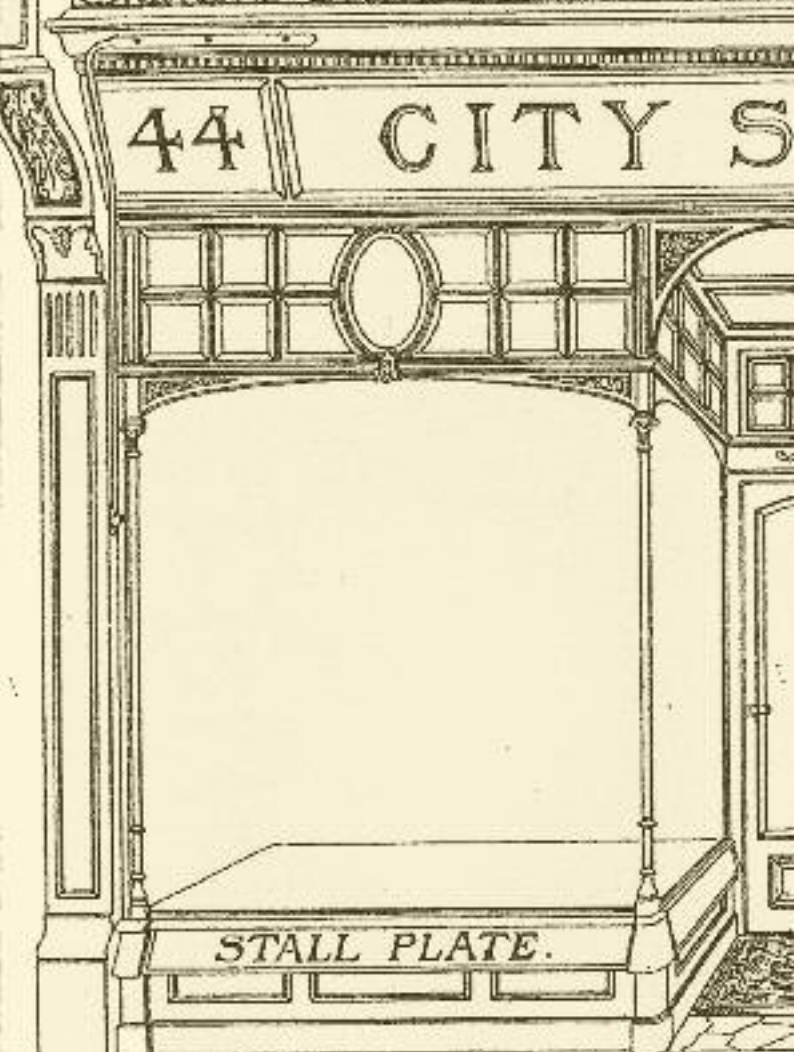
# Shop Fronts and Signage within Conservation Areas

DRAFT SUPPLEMENTARY PLANNING DOCUMENT - SEPTEMBER 2011





*drawing after Anthony Swaine, FRIBA.*



# INTRODUCTION

The Dover District Core Strategy was adopted in February 2010. The Core Strategy includes Policy DM20 – Shops. This states:

## Policy DM20

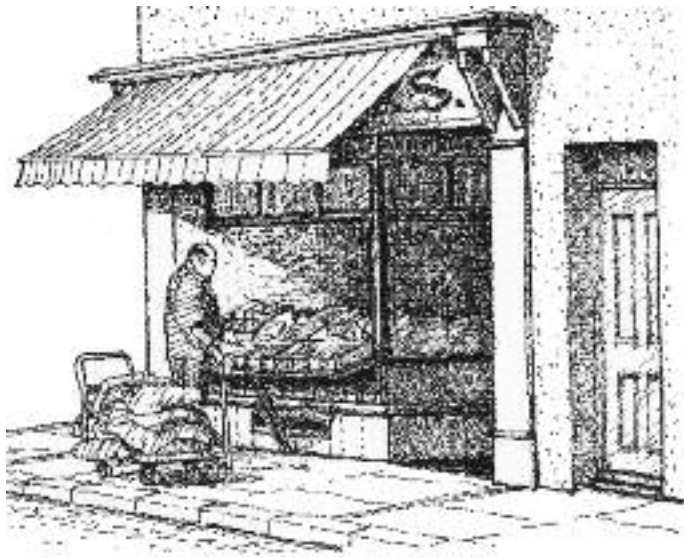
Permission for new shopfronts and alterations to existing shopfronts will only be given if the proposals respect the composition, materials and detailed design of the building and the context provided by the street in which they are located.

This SPD sets out the approach that the District Council will apply to Shop Fronts and Signage in Conservation Areas.

## The purpose of the guide.

A number of conservation areas in the District have a commercial heart and within these, the form and design of shop fronts and signs strongly influences the character of the built environment. The requirements of shopkeepers to display and advertise their goods must obviously be recognised, but at the same time it is the case that poorly designed and badly maintained shop fronts and signs not only detract from the character of an area, but are also bad for trade.

*FIG 1. There are two basic types of shop front – those which front the street and have an open window so that customers can select goods directly from them, and those in which the front is permanently glazed, and goods can only be handled within the premises. The former, shown here, is still found but is no longer common. It derives from the open market stall and often tends to colonise the pavement which can add to street vitality.*

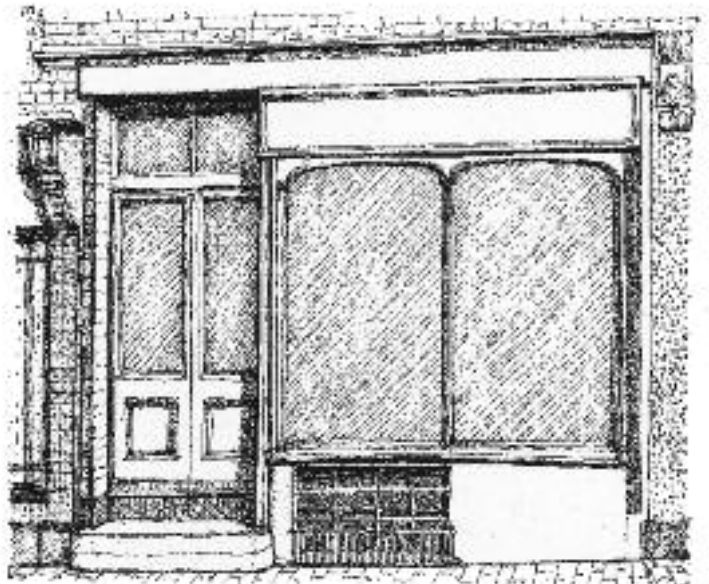


Part 1 of this guide is concerned with the overall design and individual components of the district's older shop fronts as well as the design of new shop fronts in conservation areas. Part 2 considers shop and other commercial signs in conservation areas. The guidance seeks to ensure that the design of new shop fronts and signs harmonises with and enhances the character of individual buildings and the general street scene. Whilst the principles outlined relate primarily to development in conservation areas, they can, equally, be used elsewhere in the District to ensure high standards of design.

## Design statements.

When designs for new, or changes to existing, shop fronts in conservation areas are proposed, a design statement must be submitted with any application. This must include an analysis of 'townscape' character and building characteristics in the area, together with an assessment of the visual impact made by the proposed application. The council will use the criteria set out in this leaflet when assessing planning applications for new shop fronts and advertisements within conservation areas and listed building consent applications as required.

*FIG 2. An example of the commonest type of shop front – the fully glazed-in form, which in this case dates from the end of the 19th century.*



# PART I. SHOP FRONTS

## 1) TRADITIONAL SHOP FRONTS

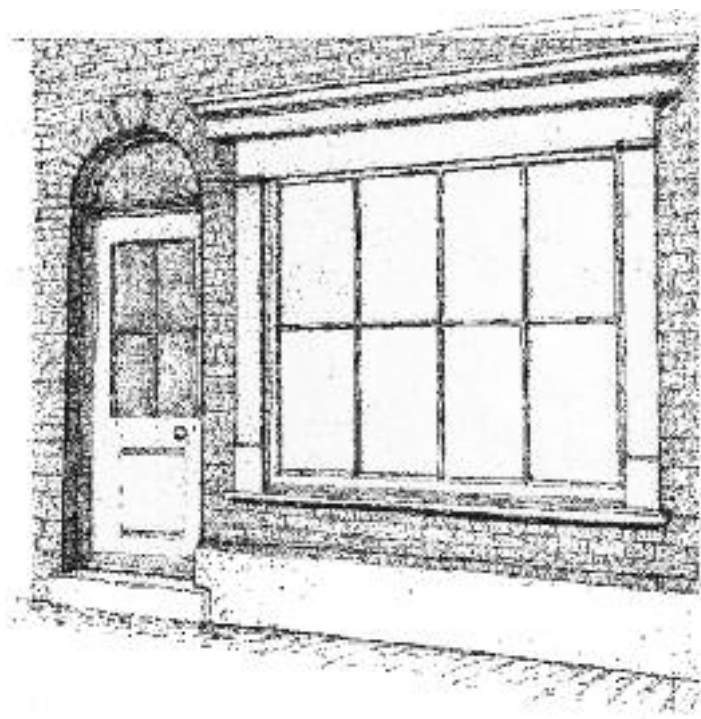
### 1.1 Shop front character

The character of traditional shop fronts arises largely from the use of a wide variety of designs, materials, colour and typography, all individually assembled or applied by specialist craftsmen. The average modern shop front with its stripped down, mass produced flat aluminium or plastic framing, crude details and factory made acrylic box fascia signboard is a very pale reflection of its historic counterpart. It is often designed for a short life span, with cheap materials failing to respect the wider visual context.

### 1.2 Types and characteristics of traditional shop fronts

A brief summary of the main characteristics of 'traditional' shop fronts is given below in the form of sketches looking firstly at their relationship with the building to which they belong and secondly at the main architectural features of traditional shop fronts.

*FIG.3. Front fitted to a hole-in-wall. This example dates from the 1840s. It follows classical precedent with a cornice and frieze, the latter being the flat board over the window on which the proprietor could paint his name and trade.*

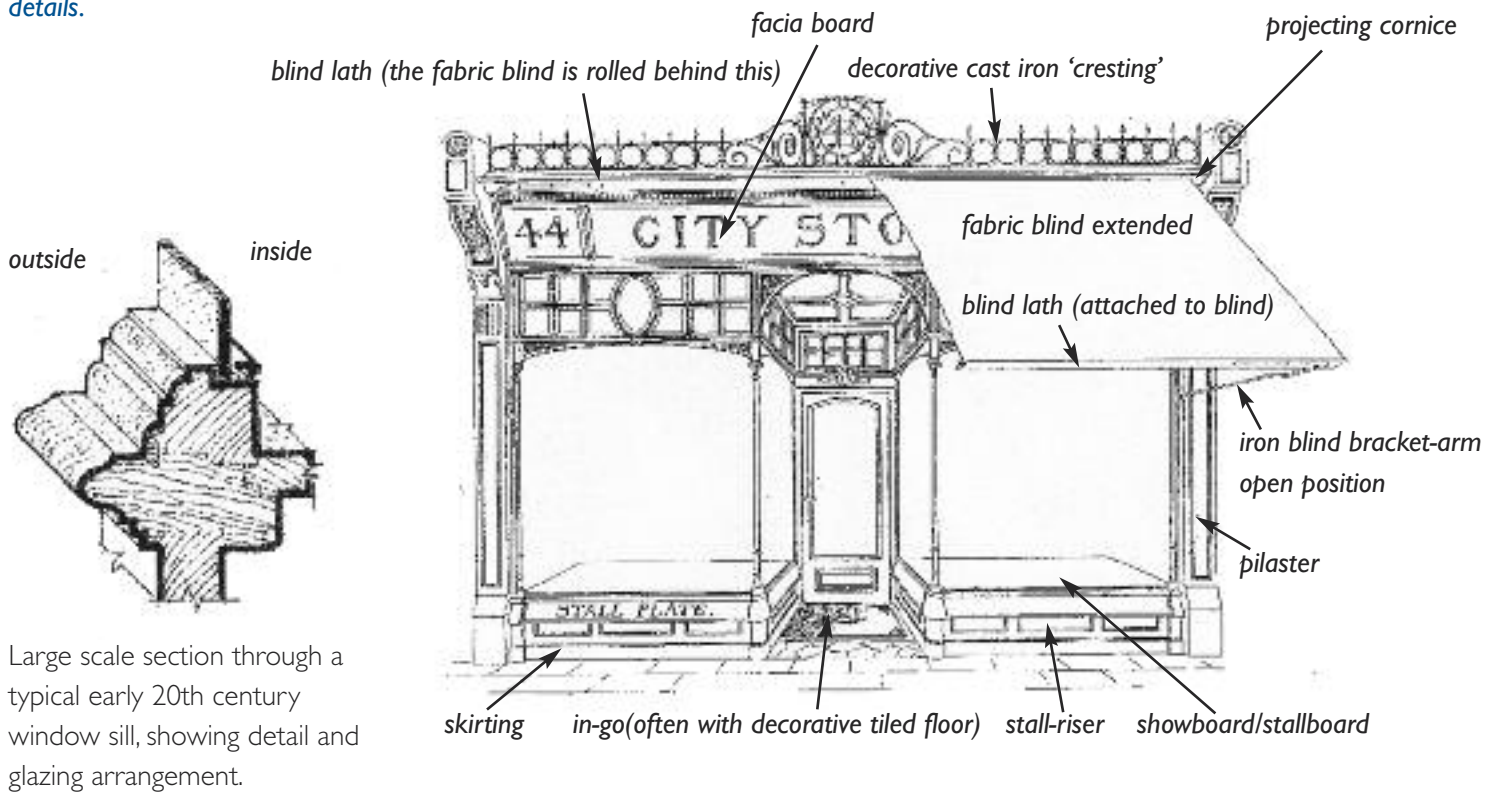


*FIG.4. Front inserted into a pre-existing building. The house is of late 18th early 19th century date while the shop front is probably Edwardian. This is a very common arrangement and many examples still survive.*



*FIG.5. Shop fronts as an integrated part of the original building design. This example shows an Edwardian mansion block with a shop throughout the ground floor. The shop front openings were often clear spanned, which allowed for easy changes at a later date. Iron columns often supported the upper floors.*

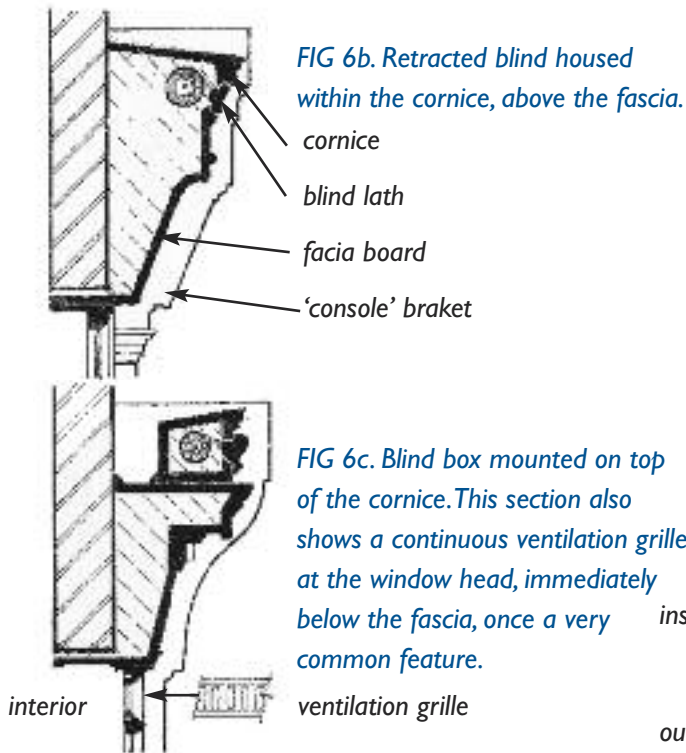
**FIG.6a. Edwardian shop front showing its main architectural features. Most of these are applicable to fronts of any age but some, such as the 'cresting' on top of the cornice and the very slim window mullions to each side of the in-go, are 'period' details.**



Large scale section through a typical early 20th century window sill, showing detail and glazing arrangement.

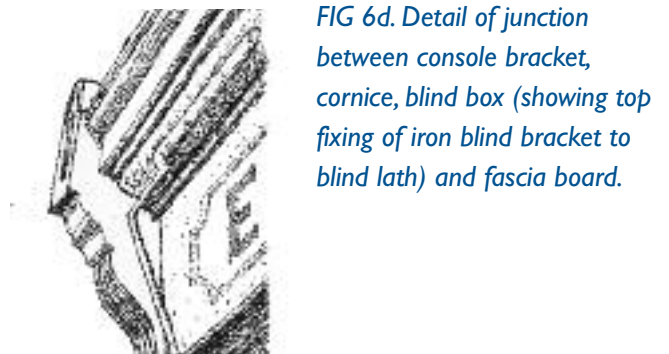
**Blind boxes, basement vents and window mullions**

Detail sections through two varieties of Edwardian fascia/cornice in which roller blind boxes are catered for:

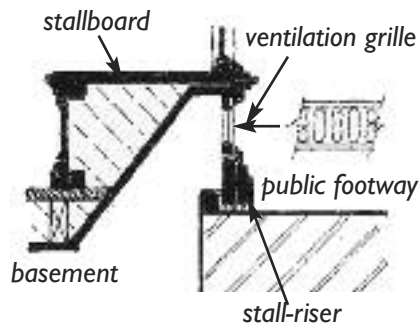


**FIG 6b. Retracted blind housed within the cornice, above the fascia.**

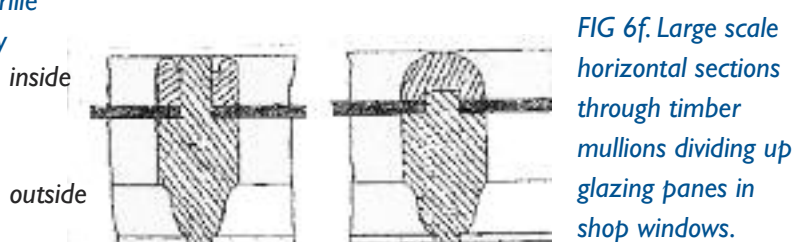
**FIG 6c. Blind box mounted on top of the cornice. This section also shows a continuous ventilation grille at the window head, immediately below the fascia, once a very common feature.**



**FIG 6d. Detail of junction between console bracket, cornice, blind box (showing top fixing of iron blind bracket to blind lath) and fascia board.**



**FIG 6e. Section through a stall riser and stallboard at the foot of a shop window showing low level ventilation to a basement, set within the stallriser**



**FIG 6f. Large scale horizontal sections through timber mullions dividing up glazing panes in shop windows.**

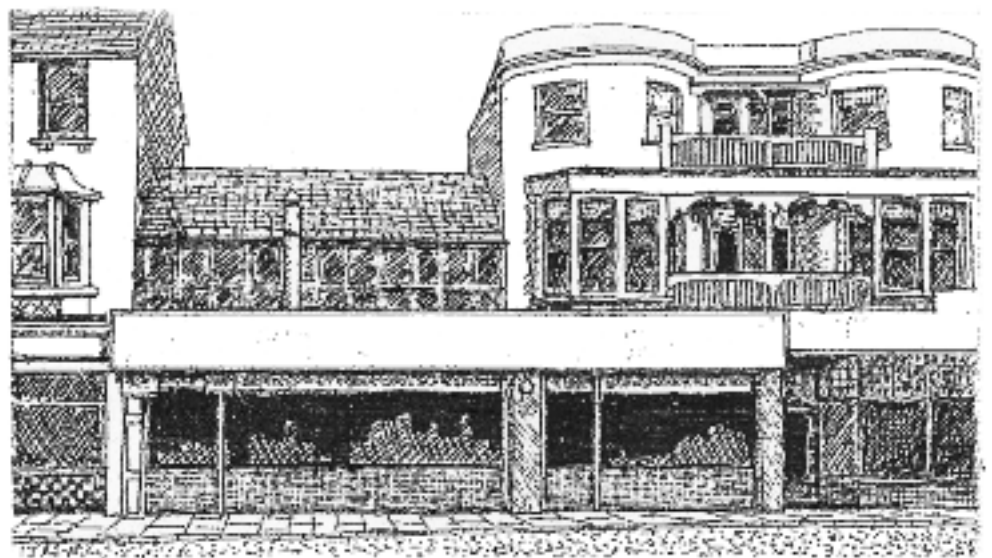
## 2 RELATIONSHIP OF SHOP FRONTS TO THE GENERAL STREET SCENE.

Most traditional shop fronts are variations on the theme of stall riser, pilasters, fascia signboard and cornice. A series of old fronts side by side can act to unify the picture, giving overall visual coherence to the street scene. At the same time, at an individual scale they can offer interest and variety through their varying detail and materials.

*FIG.7. These traditional shop fronts inserted into the ground floors of earlier buildings are variations on the same theme and form a coherent group.*



*FIG.8. The central shop occupies a one and a half building width, its deep fascia signboard carried across both frontages. The new fascia should at least have been sub-divided vertically to reflect the separate integrity of the buildings above it.*



An effect of consistent scale and architectural 'rhythm' (resulting from the use of separate repeating elements all following a basically similar design theme) is often a feature of groups of old shop fronts and the buildings into which they are fitted. This is easily damaged by the introduction of poorly thought out modern designs. The scale and bland, shiny appearance of very large, undivided and horizontally proportioned shop window glazing can have a particularly damaging effect on the character of a conservation area. Examples are the central and right hand shop fronts in FIG 8 which are poorly designed and unrelated to the earlier buildings which contain them. In appearance, arrangement and scale the new work is completely different from the original work, undermining the coherent character of the original buildings.

### 3 GENERAL SHOP-FRONT DESIGN PRINCIPLES

#### 3.1 Existing traditional shop fronts or parts of shop fronts

If an historic shop front or parts of one, already exists at a site where development is proposed, there will be a presumption in favour of retention in order to protect conservation area character. Where good traditional features of interest remain, for example coloured mosaic or encaustic tiling, door-cases, fanlights, cast iron ventilation grilles over windows or stained or etched glass, they should be retained. Earlier, hidden, historic features, particularly original decorative glazing to upper parts of windows, console brackets and pilasters, can sometimes be exposed from behind modern shop fronts at little extra cost and brought back into use to improve the character of the conservation area. Tiling to 'in-go' floors often survives and should always be retained.



*FIG.9. The front (probably of early 20th century date) on the far left is contemporary with the building. The door to its left hand side leads to a stair to the upper levels. The shop entry is via an off-centre in-go placed to catch the eye of passers-by. The signboard is of the traditional shallow depth, the window display 'reading' as the shop's main advertisement. By contrast the adjacent deep modern signboard competes visually with the window below and is too large for the building. It conceals the original shallow depth fascia which could easily be exposed to bring back an element of design quality to the overall composition.*

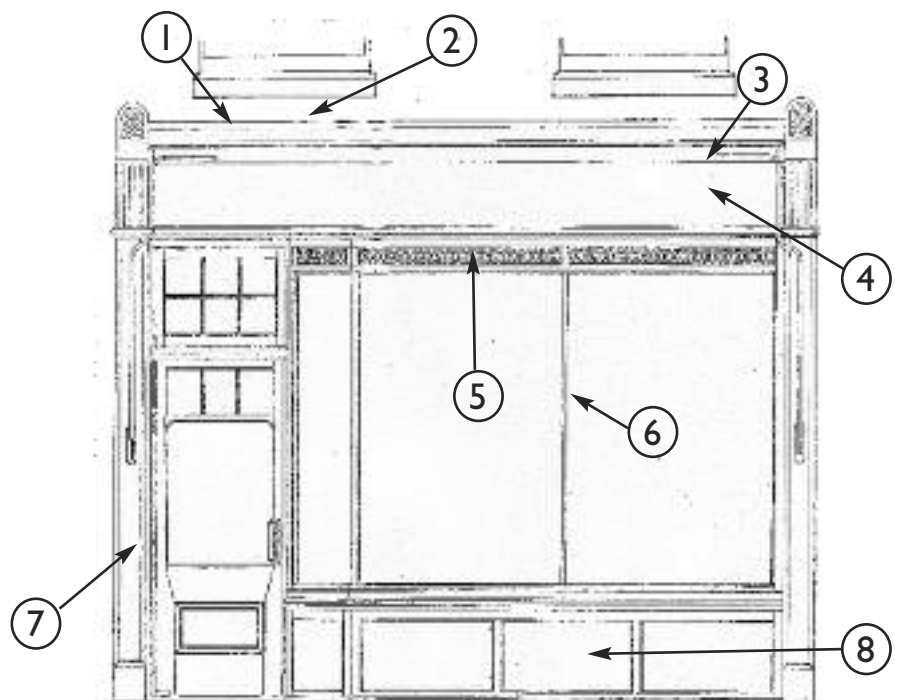
#### 3.2 New shop fronts

As noted earlier, the appearance of new shop fronts set in existing buildings should take account of the character of the building in which they are located and the wider street scene.

Above all, the new shop front should respect the particular design of the building which contains it. If the building is modern the new shop front may reflect this but should also adopt some of the basic principles of traditional shop front design present in the wider street scene.

*FIG.10. Historic shop front design used to show key shop front features.*

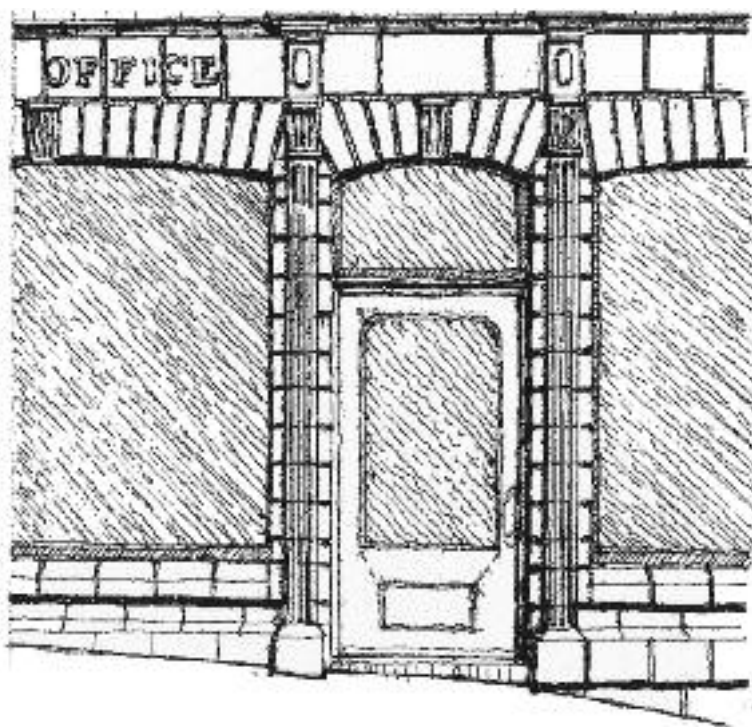
- 1) A cornice should be provided on top of the fascia/signboard as a visual break between the shop front and the upper floors of the building.
- 2) Where possible a gap should be left between the cornice and the window cills of the first floor windows.
- 3) Traditional retractable canvas blinds are aesthetically pleasing and functionally useful.
- 4) The height of fascia/signboards should be kept to a minimum and should not be visually overbearing in relation to the overall height of the shop front. They should be made of wood or a non-reflective material.
- 5) Appropriately designed fanlights and ventilation grilles can be used to provide ventilation.
- 6) Large vertically undivided expanses of glass should be generally avoided. Windows should be sub-divided by mullions or a central doorway.
- 7) Shop fronts should usually be framed with pilasters to help to emphasise the sub-divisions between buildings.
- 8) Stallrisers in timber, render, glazed tiling or even sometimes brick, should always be incorporated.



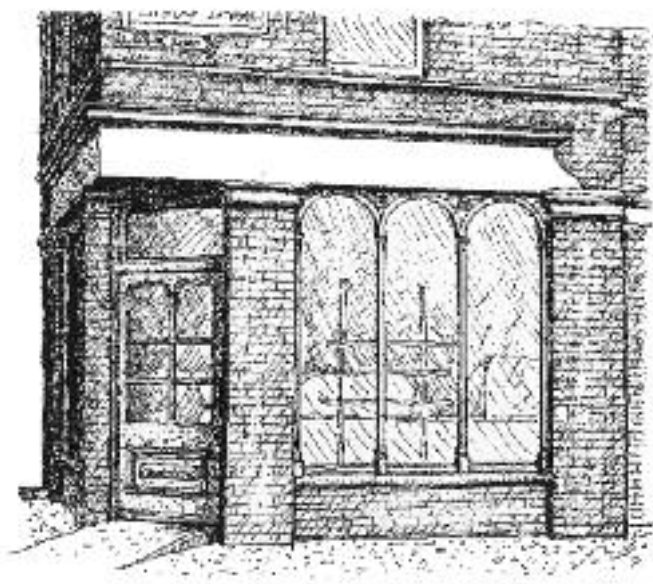
### 3.3 Materials and colour

Materials that are likely to be acceptable in conservation areas include timber (usually painted), occasionally quality gauged brick, rendered brick or block, stone, terra-cotta, cast iron, bronze, copper and brass, glazed tiles, mosaic tiling, glass (etched, bevelled and engraved) and paint. Timber remains one of the most suitable materials for window and door frames and fascia/signboards. Modern materials such as plastic laminates, glossy perspex and aluminium are unlikely to be acceptable.

*FIG. 1 | a,b&c. Show some examples of the relationship between materials and design in historic shop fronts.*

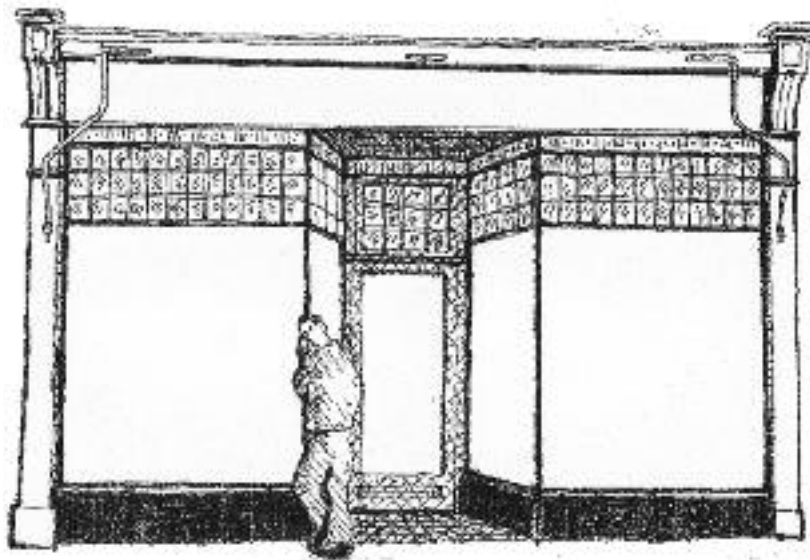


*FIG. 1 | b. Terra-cotta facade, Victorian or Edwardian. Everything here is formed of separate purpose designed fired clay units affixed to a backing of brick and steelwork. Joints of the arches and pilasters are expressed as 'rustication'. Even the fascia follows this theme.*



*FIG. 1 | a. Classic purpose designed late Victorian or Edwardian 'corner shop' with windows on two streets. Wooden shop window with brick stall riser, framed between substantial brick piers.*

In the past colour schemes were normally individually produced to emphasise the style of the shop front and to show off the goods on display in the best light. Today colour is often used to make the shop front itself a form of advertising. This approach, seen especially with corporate colour schemes that are applied regardless of the character of the 'host' building or of the location, is generally not acceptable in conservation areas.

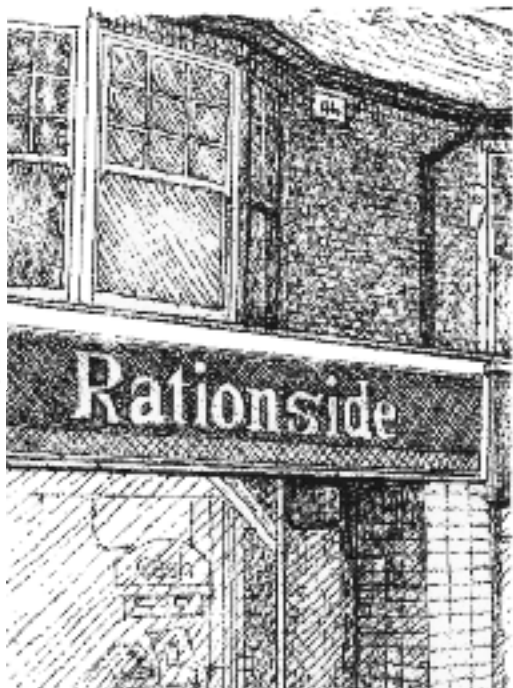


*FIG. 1 | c. Economical early 20th century front with black and white tiled 'in-go' floor, polished black marble stall risers, large (still vertically proportioned) areas of glazing, very slender bronze sills, mullions and transoms, continuous high fixed multi-pane coloured glazed fanlight section, continuous decorative window head ventilation grille, panelled ceiling to 'in-go', flat wooden fascia with blind box and small cornice over.*



### 3.4 Shop fronts and corporate identity

The need for the shop front to have an appropriate architectural relationship both to its 'host' building and to the conservation area will be judged as more important than the need for corporate identity, should the two come in conflict with each other.



*FIG. 12. A shop front replacing a previous one that was related architecturally to the first floor façade. The deep, flat, box-fascia is over scaled for its location. The single paned shop window is framed in narrow flat strips of stainless steel and the flat sides of the pier on the right are clad in shiny glazed tiles. These features are not acceptable as they detract from the character of the building.*

### 3.5 Shutters and blinds

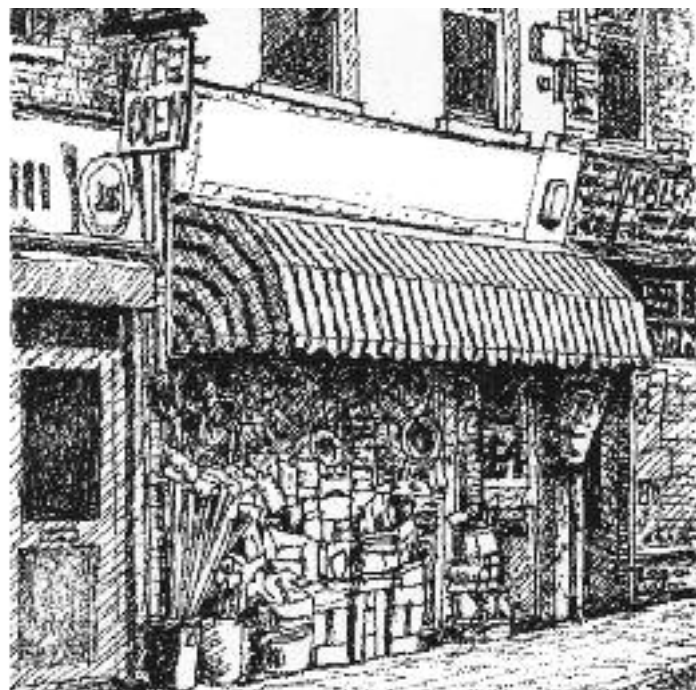
Whilst exterior roller shutters have been used for shop front security since Victorian times, in conservation areas their appearance is not generally appropriate. This is principally because their fortress-like aspect when closed has a visually deadening effect on the street scene. Where high value goods need protection then the open lattice type of roll down grille, set inside the window, may be an acceptable alternative. Traditional canvas and iron-arm roller blinds designed to retract into blind boxes integrated with the shop front will normally be acceptable where protection from the sun is required.



*FIG. 13. A canvas blind with modern (hidden) support arms.*

### 3.6 Non-retractable blinds

The modern alternative 'Dutch blinds', fixed in the open position, are always prominent features in the streetscape. Their particular convex curved and often shiny form is visually intrusive and permanently conceals large parts of the shop fronts to which they are fixed. These, and similar non-retractable modern shop front blinds and awnings are unlikely to be acceptable in conservation areas.



*FIG 14. An example of a fixed 'Dutch blind'.*

### 3.7 Further security advice

For further more detailed advice on security measures please see the Council's Supplementary Planning Guidance leaflet 'Security Measures for Retail and Commercial Premises'.

## 4 SHOP FRONT FEATURES NOT APPROPRIATE IN CONSERVATION AREAS

### 4.1 Unsuitable features/alterations

As already indicated the design of modern shop fronts often fails to respect the architectural character of the buildings into which they are built as well as disregarding the local character of individual conservation areas. Some undesirable features of modern designs which commonly conflict with historic visual 'contexts', and which are to be avoided, are shown on Fig.15.

FIG.15. Undesirable features in an historic building.

1) Fascia too deep.

*It is encroaching over first floor window cills*

2) Oversized and clumsy lettering.

3) Crude glass or flat metal louvers over doorway.

4) Aluminium or plastic door/window frame of visually uninteresting, flat, cross-sectional design, lacking individuality.

5) Display window.  
*The uninterrupted area of glass is too large for the overall scale of the building. The shop front also lacks a stallriser.*

6) Close spaced row of visually intrusive overhead lights

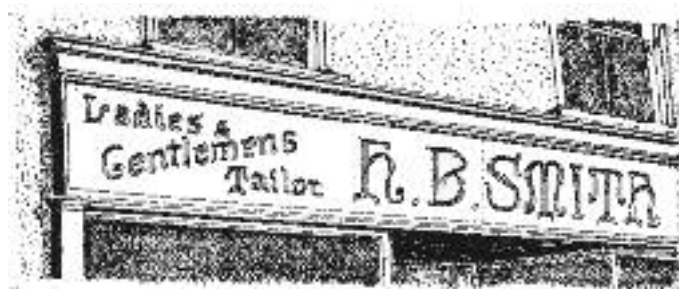
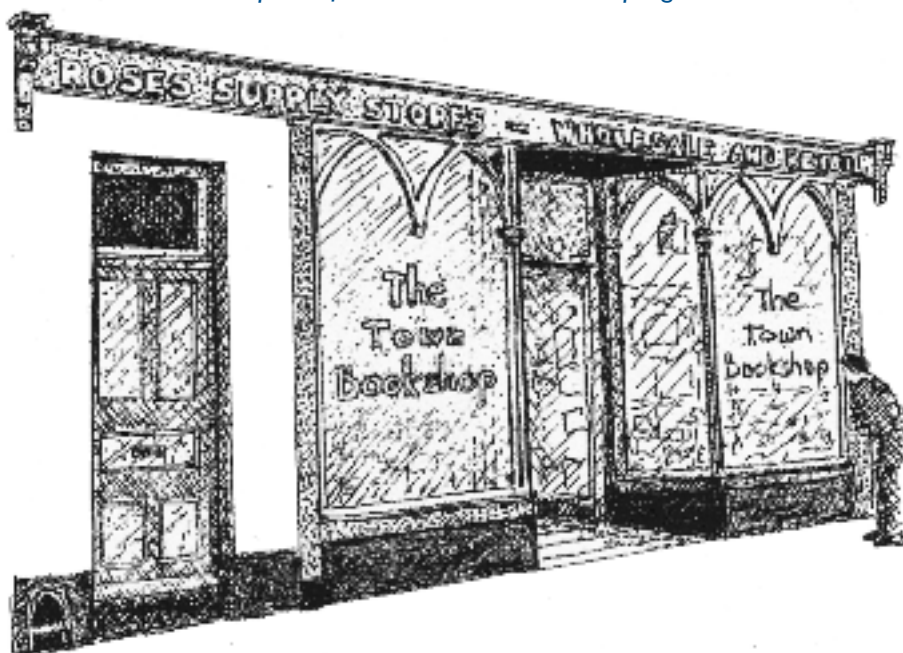


## PART 2. SHOP SIGNS

### 5 Shop signs and their importance to conservation areas

The need for shopkeepers to make their presence known in the street through advertising is recognised. The challenge in conservation areas is to make sure that this is achieved in a way that does not detract from the character of the area. While well designed shop signs coupled with pleasing and appropriate shop fronts can add visual quality to an area, poor design damages its overall appearance. The proliferation of even small signs, if badly designed and made from unsuitable materials can have a damaging visual effect over a large area. It is important to realise that each shop front and each element in that shop front, including the advertising, contributes to the character of an area.

*FIG. 17. An earlier shop signboard with cut-out individually mounted letters contributes to conservation area character. Details of the present use are painted on the shop windows below.*



*FIG. 16. 19th century signboard of slate with incised lettering, exposed from behind a modern shop signboard.*

### 6. TRADITIONAL SHOP SIGNS

#### 6.1 Types of fascia sign

The most common form of sign is that of lettering on a fascia board. Before the middle of the 20th century signs were made to various levels of complexity and in a variety of ways. Thus lettering was sometimes painted direct to the wall, a separate signboard might be very simply hand painted, a more elaborate sign design and hand painting scheme might be applied, lettering might be cut into the sign board (stone or slate) and gilded or it might be individually cut out and applied to the board to give a raised effect. Occasionally designs were set behind glass. Enamel signboards were sometimes employed, often by commercial enterprises,

The list is not exhaustive.



*FIG. 18. Detail of cut-out and raised lettering.*



*FIG. 19. Sign painting direct to a rendered wall-face framed in moulded brick.*

## 6.2 Hanging signs

Hanging signs, bracketed off the building by means of iron supports at right angles, have been in use for some centuries. Sometimes they were designed as hanging objects, often emblems of a particular trade or speciality. Those painted onto a rectangular board, however, were in recent historical times probably the most common.

The lower edge of hanging signs should not come below 2.5 metres above the footway and they should not project over the highway or conceal traffic signs. Signs should be hung from simple traditional iron brackets and should usually be made of timber and hand painted. Sign content should be kept simple. Trade symbols such as the chemist's pestle and mortar are welcome details.

## 7. GENERAL SHOP SIGNBOARD AND PROJECTING SIGN DESIGN PRINCIPLES

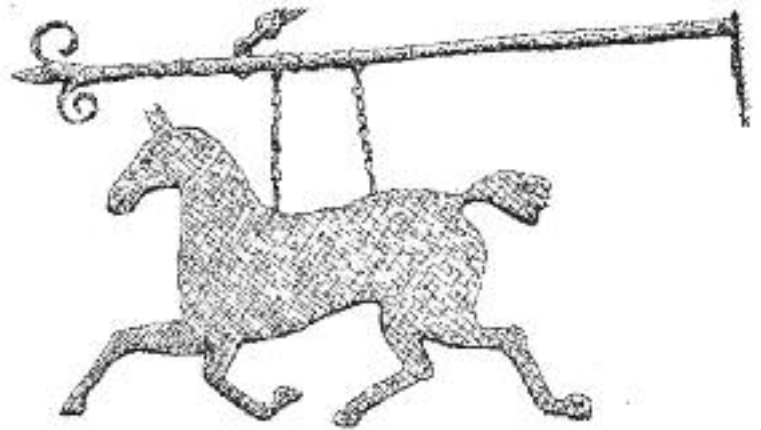
### 7.1 Fascia sign boards

A single clear sign is better than several confusing ones – there is no point in saying the same thing more than once. Matt finish signboards and hanging signs with hand painted lettering are preferred. Other traditional design, material and finish arrangements of the kind described earlier are also likely to be acceptable.

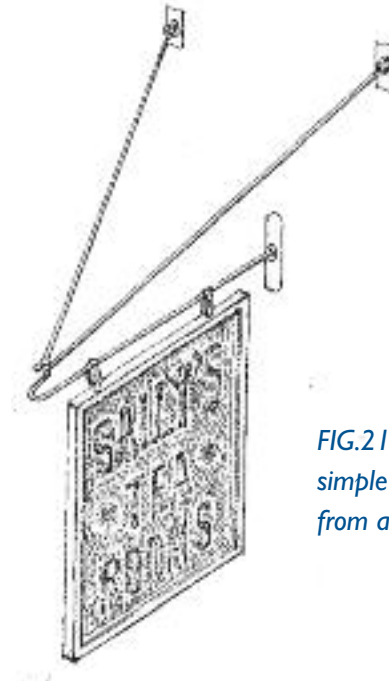
### 7.2 Lettering and colour

Lettering should be proportionate to the size of the fascia or hanging sign which should in turn be proportionate to the elevation of the building on which it is mounted. Generally a margin or border should be left between the sign writing and the edges of the fascia, at top and bottom as well as at the sides. A wide variety of type faces may be acceptable but those derived from pre-computer age designs are likely to be more appropriate to their large scale 'architectural' situation. The range of lettering used in recent tradition was often drawn from the four great 19th century English type face categories of Clarendon, Egyptian, Grotesque and Decorative with the addition of pen and brush derived Scripts. The use of a wide variety of colours is possible but modern 'florescent' paints are not acceptable.

*FIG.22. Upper case examples of five basic type face groups recommended for signs with examples of shadowed versions of the first four of these type faces.*



*FIG.20. Traditional iron hanging sign in the form of a horse.*



*FIG.21. Wooden hanging sign with simple iron bracket arm supported from above by two angled stays.*



'Shadow'

### 7.3 Lettered signs and designs on, or behind, shop windows and doors

This was an infrequently used traditional option, where a window display was not important as in the case of public houses, especially those of the late Victorian and Edwardian periods. Carefully considered sign-writing on the shop window can sometimes prove useful where there is, for instance, difficulty in using the shop fascia board, or where this is absent.

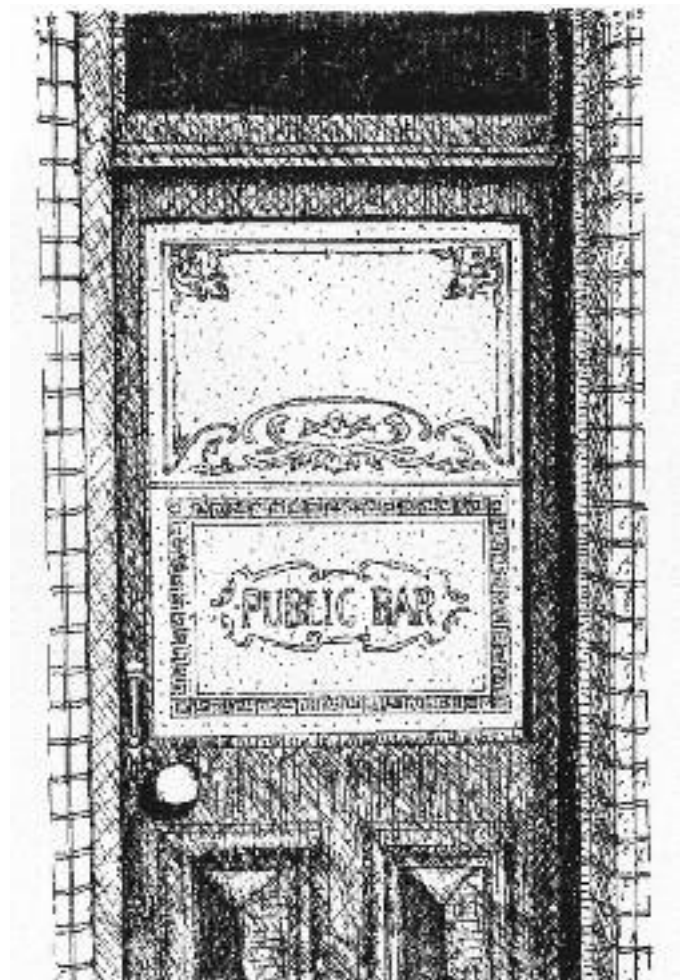


FIG.23. Late Victorian/Edwardian decorative etched glass.



FIG.24. Example of lettering applied to window pane.

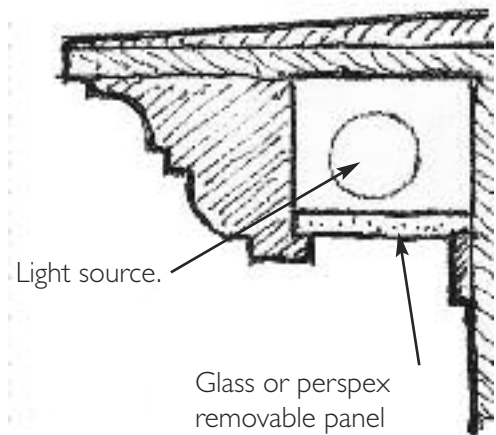
### 7.4 Signs for businesses in upper floors

Signs for businesses in upper floors could take the form of lettering applied directly to window panes.

## 7.6 Sign lighting

Externally mounted trough lights may be acceptable in some circumstances but should form part of the overall design and not appear as an afterthought. Carefully arranged trough lighting designed as an integral part of the fascia and housed in the soffit of an overhanging cornice moulding, can work well. Discreet spot-lighting of signboards may sometimes be appropriate. Arrays of swan-necked lights to illuminate signboards produce unacceptable visual clutter (see fig 15).

FIG.25. Cross section of cornice containing exterior strip lighting for signboard below it.



Lighting contained within projection cornice



## 8. SHOP SIGNS AND MATERIALS UNSUITABLE FOR USE IN CONSERVATION AREAS

### 8.1 Corporate identity

The national house styles of multiple stores will often not be acceptable as they generally involve the use of designs and materials not visually related to, or developed from, the particular conservation area context within which they are proposed.

### 8.2 Modern materials and the size of signs

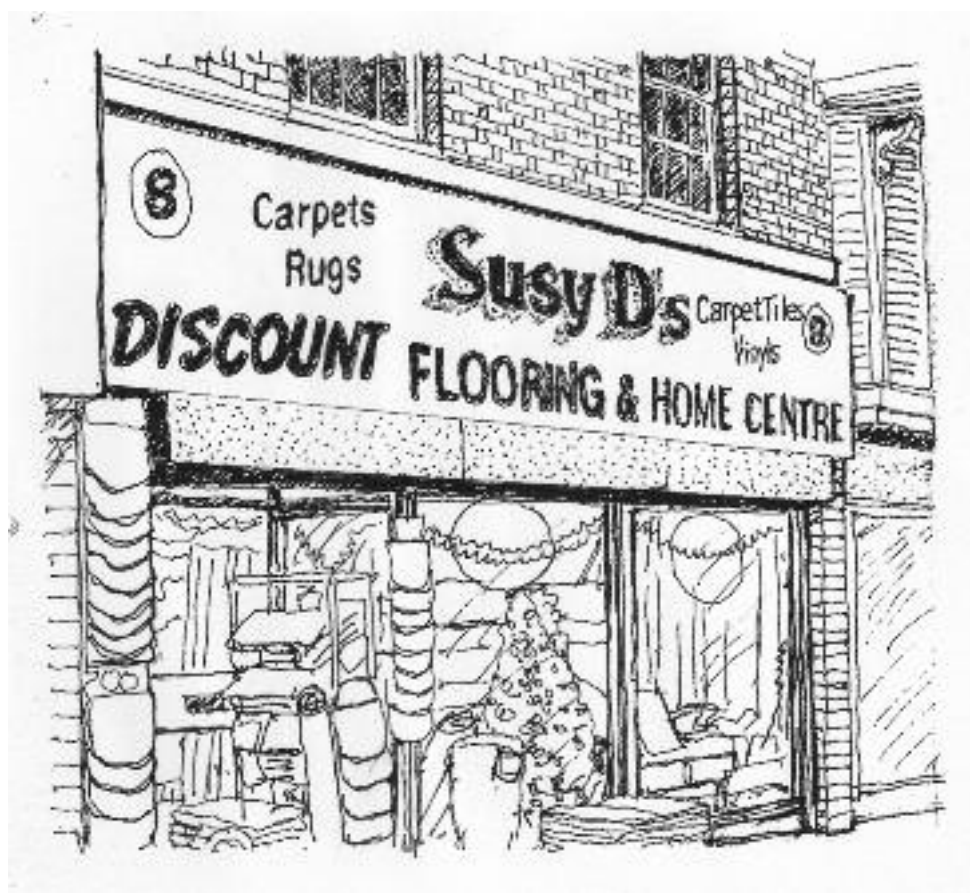
Garish and reflective modern materials should not be used. Excessively deep-lettered fascia boards (signboards) that are out of proportion with, or dominate visually, the overall elevation within which they are fixed are likely to be out of place in conservation areas.

### 8.3 Internally illuminated modern projecting box signs and box fascias & 'cut-out' box signs and fascias with individually illuminated letters.

These types of signage are not appropriate within conservation areas.



*FIG.26. A restaurant in an historic building in a conservation area showing an appropriate treatment of the company's house style, in order to respect the individual building and the wider historic context.*



*FIG.27. An example of signage in common use but unacceptable in conservation areas. The signboard is too deep for its location on a traditional brick building. The metal box containing an external roller shutter is crudely exposed below the signboard, adding to the latter's effect of depth. A number of different type fonts are employed on the signboard and this together with their detailed relationship to one another, gives visually competing messages. One main message should stand out.*

## Sustainability Appraisal

Sustainability Appraisal (SA) of Development Plan documents is required in the UK by the Planning and Compulsory Purchase Act 2004. However, the 2008 Planning Act has removed the requirement for carrying out SA of SPDs. This came into force on 6th April 2009 with The Town and Country Planning (Local Development) (England) (Amendment) Regulations (2009).

Policy DM20 of the adopted Core Strategy sets out the requirements for new shop fronts and any alterations. As this Policy has been assessed as part of the SA to the Core Strategy and this SPD is simply the 'delivery vehicle' for how Applicants can achieve the shop fronts that would meet the objectives of Policy DM20 in Conservation Areas, an SA of this Shop Fronts and Signage within Conservation Areas SPD is considered not to be necessary.

## Further Reading.

Shopfronts and Advertisements in Historic Towns, English Historic Towns Forum (1991).

Book of Details of Good Practice in Shopfront Design, English Historic Towns Forum (1993).

Shopfront Pattern Book, Hove and Brighton Joint Urban Conservation Board, (1995).

Shopfronts, English Heritage Listed Building Guidance Leaflet (London 1990).

Modern Practical Joinery, G. Ellis (London 1987, reprint of 1908 edition).

The English Lettering Tradition from 1700 to the Present Day, A. Bartram (London 1986).

Shopfronts, Alan Powers (London 1989).

Nation of Shopkeepers, B. Evans and A. Lawson, (London 1981).

Security Measures for Retail and Commercial Premises, Dover District Council Supplementary Planning Guidance leaflet. Jan. 2002.

Dover District Council  
White Cliffs Business Park  
Dover  
Kent CT16 3PJ

01304 821199  
[www.dover.gov.uk](http://www.dover.gov.uk)

